

## A High-Resolution Continuous Pressure Sensor Modification for Radiosondes

ROY I. GLASS, RALPH D. REYNOLDS AND ROY L. LAMBERTH

*Atmospheric Sciences Laboratory, White Sands Missile Range, N. Mex.*

(Manuscript received 28 August 1967)

### ABSTRACT

This paper describes how continuous pressure measurements may be obtained by making a relatively simple modification to any standard or clock-switched radiosonde which can be flown on a rising or floating balloon. The continuous pressure device is composed of an aneroid sensor which controls the frequency of a subcarrier oscillator. Frequency modulation of the radiosonde transmitting tube is used instead of amplitude modulation. The receiver for this system utilizes the standard GMD-1B ground tracker with a special demodulator, the standard TMQ-5 recorder, and a frequency counter with printer. Each pressure sensor is calibrated for frequency vs. pressure; precision of reading the pressure is to 1 mb as currently used, but readings to 0.1 mb are easily obtainable.

Pressure data from three superpressure balloon flights are presented to show the detail obtained by the instrument with this modification. This modified instrument provides the research meteorologist with a new inexpensive research tool.

### 1. Background

Investigations of mountain waves at White Sands Missile Range, N. Mex. (WSMR) have previously been reported (Lamberth *et al.*, 1965). The primary tool for studying the dynamics of these waves is the radar tracking of superpressure balloons. AMT-15 radiosondes are used with these balloons to provide simultaneous sensing of the meteorological parameters of pressure and temperature since the clock sequencing of the data precludes reliance on the baroswitch for sampling. The use of the baroswitch permits only one quantity to be transmitted for a period of many minutes on a floating balloon.

Computations utilizing the ambient temperature and pressure measurements were needed to determine the isentropic surfaces and to delineate the flow of an air parcel associated with a mountain wave. In the first flights of the program, erratic temperature readings were observed. Investigation of this problem (Reynolds and Lamberth, 1966) led to the modification of radiosondes whereby the thermistor is suspended approximately 4 ft below the radiosonde. This "dangling" thermistor is outside the thermal boundary layer that exists around a balloon and train when floating during daylight hours.

Pressure measurements were initially made with the baroswitch commutator since the flights were not high enough to utilize the hypsometer. In some mountain waves with wave heights of 1 km, the baroswitch recorded only three reference points within this interval which resulted in insufficient resolution. Also, the uncertainty introduced by linkage hysteresis was present. A need was thus apparent for a method to measure

pressure variations by radiosonde in much greater detail. This has also been noted by other investigators (Suomi *et al.*, 1967).

### 2. Approach

The approach taken in solving the pressure problem involved adding a unique high-resolution pressure sensor (HRPS) to the AMT-15 radiosonde. This HRPS measures pressure continuously and is made basically of an aneroid element which controls the frequency of a subcarrier oscillator. This is accomplished by attaching a ferrite slug directly to the free end of the aneroid. Movement of the slug within the oscillator tuning coil varies the inductance, hence the frequency of oscillation.

A modified Colpitts oscillator circuit is utilized with

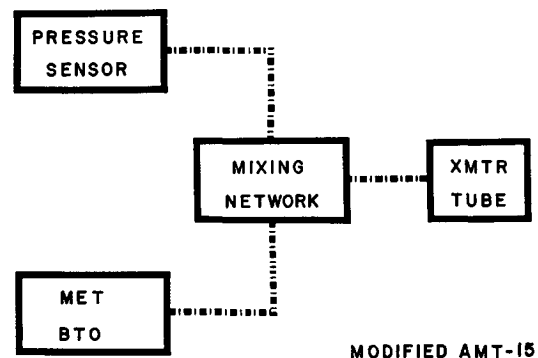

FIG. 1. Block diagram for the flight unit for either the clock-switch AMT-15 radiosonde as used at White Sands Missile Range or for the standard AMT-4 with baroswitch. The standard meteorological blocking tube oscillator (BTO) and pressure sensor are fed through the mixing network to the transmitter tube.

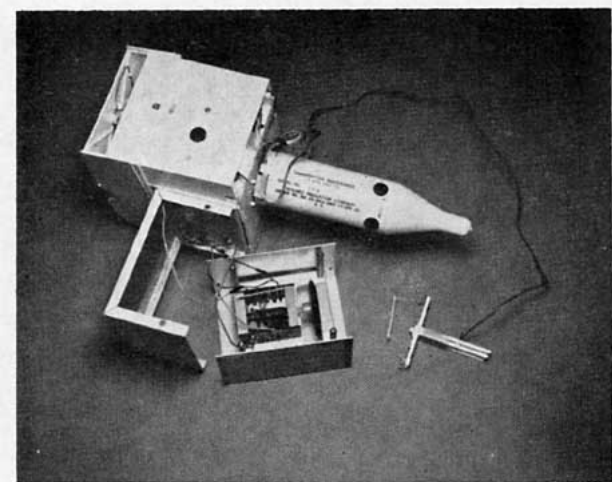

FIG. 2. Open view of the High Resolution Pressure Sensor (HRPS) below the radiosonde case. The aneroid element varies the frequency of a subcarrier oscillator by the movement of a ferrite slug. Notice the radiosonde thermistor that is installed on the HRPS sensor to give the temperature inside the case. The "dangling" thermistor is to the right of the HRPS.

added temperature stabilization capacitors and in turn is coupled to the AMT-15 through an isolation stage and thence to the grid of the transmitting tube. The nominal operating frequency is 60-67 kHz. Fig. 1 is a block diagram of the flight unit.

Frequency modulation of the transmitting tube is employed in place of the standard amplitude modulation. This permits frequency division multiplexing of the HRPS and blocking oscillator signals. A reduction in amplitude of the blocking oscillator pulse is necessary to obtain proper mixing and is accomplished with a Zener diode circuit. Fig. 2 is a view of the modified AMT-15 with the HRPS container open.

A small insulated box attached to the modulator housing of the AMT-15 contains the pressure sensor.

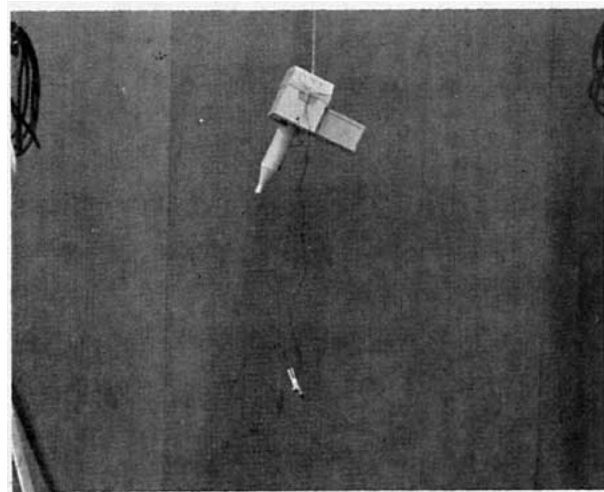

FIG. 3. Complete HRPS radiosonde assembled in launch configuration.

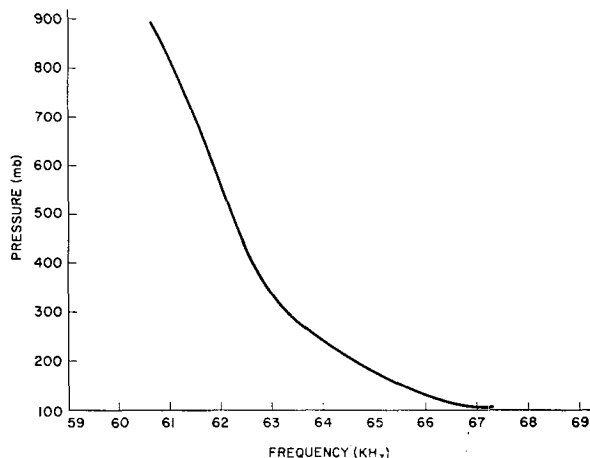

FIG. 4. Pressure vs. frequency calibration in a pressure chamber. The nominal operating frequency range is 60-67 kHz. This is a typical chart showing the linear response in the pressure-altitude from 900-400 mb as used at White Sands. Pressure resolution is obtainable to 0.1 mb.

Power is derived from the radiosonde filament battery through a Zener diode voltage regulator. The complete unit weights 2.6 lb excluding battery. Fig. 3 shows the complete unit with the attached HRPS container and the dangling temperature sensor.

The pressure sensor is calibrated in a pressure chamber. A typical calibration curve (Fig. 4) presents pressure as a function of frequency. The calibration chart may be read to the nearest 1.0 mb under these test conditions, but resolutions of 0.1 mb are easily obtainable. The pressure-frequency relationship is fairly linear in the range of 900-400 mb which is the range of interest at WSMR. The HRPS calibration procedure also includes a correction for temperature (Fig. 5). A thermistor is mounted on the oscillator inside the insulated HRPS

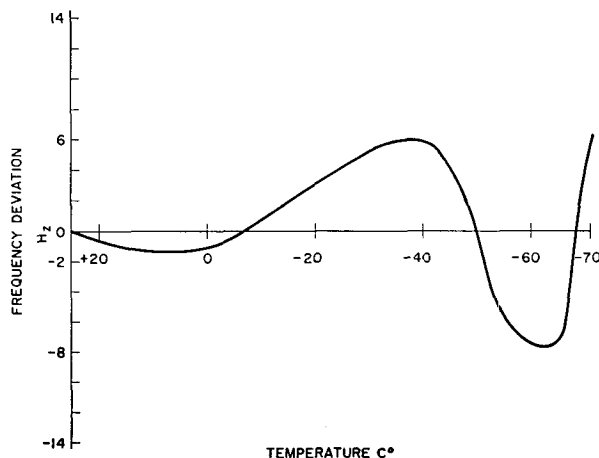

FIG. 5. HRPS corrected for temperature. This temperature calibration curve is not as bad as it seems; test flights have shown that the temperature of the oscillator in its insulated case remains very constant even when the atmospheric temperature is changing 10-15C.



FIG. 6. The demodulator used with the HRPS. This connects the GMD-1B ground tracker with a frequency-counter and printer for pressure data and connects the GMD to the TMQ-5 for the other standard meteorological data.

case (Fig. 2), and its temperature and ambient temperature are recorded. The temperature of the oscillator has been found to be very constant on test flights even when the atmospheric temperature varies by as much as 10-15C.

Receiving equipment utilized with the system is made up of an AN/GMD-1B meteorological tracker with a special demodulator, a TMQ-5 recorder, and a frequency counter with an associated printer. The demodulator accepts a signal from the FM output of the GMD receiver section after a slight modification of the receiver for proper impedance matching.

In the demodulator (Fig. 6), pressure data are separated from the composite signal with a high-pass filter

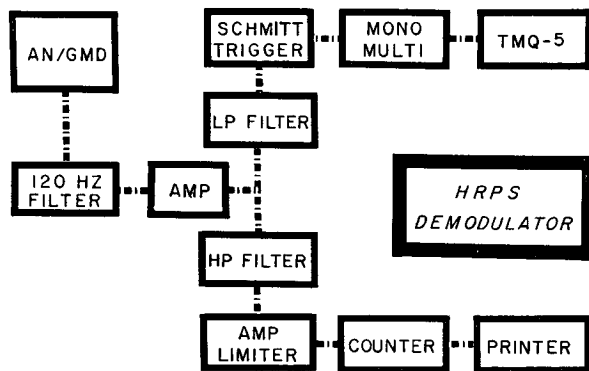

FIG. 7. Block diagram for the HRPS demodulator. Shown are the integral units between the GMD-1B ground tracker and the standard TMQ-5 recorder which records the ambient temperature and temperature from the oscillator on one hand, and the counter and printer which records the frequency.

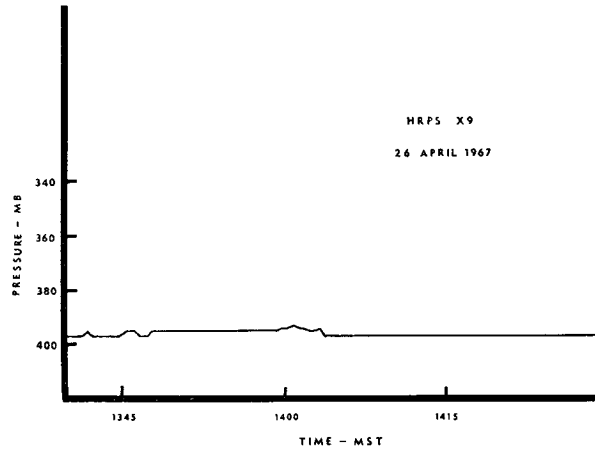

FIG. 8. Control case flown when there was no mountain wave present. Notice the relatively smooth pressure trace. The balloon passed over the crest of the mountain at 1350 MST.

section and then amplitude limited. Frequency measurement is accomplished with a conventional electronic counter and the output is recorded continuously on a digital printer. The printer record includes the time obtained from a built-in digital clock.

Temperature data pulses are separated from the incoming signal with a low-pass filter and are reshaped with a Schmitt trigger and monostable multivibrator circuit combination (Fig. 7). The TMQ-5 records the data. A 120-Hz notch filter is used in the line from the receiver to the demodulator to reduce hum pickup from the GMD.

### 3. Results and conclusions

Three field tests of the modified radiosonde were conducted at WSMR. A control case where no wave existed is shown in Fig. 8. The absence of any wave motion of the balloon during this control test was verified by radar data from the AN/FPS-16 radar.

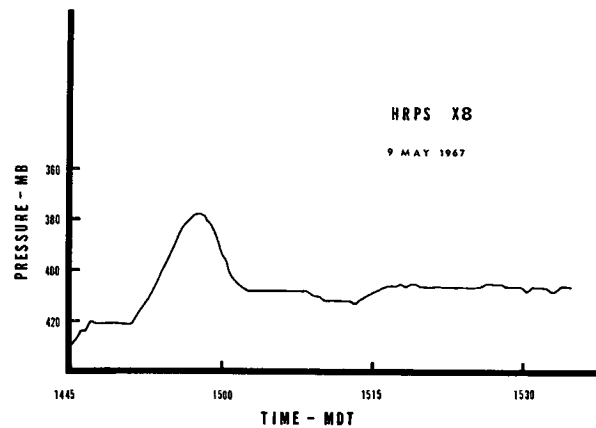

FIG. 9. Flight showing an unusual pressure configuration to the lee of the mountain where recorded pressure indicates a decrease at the mountain interface. The balloon passed over the crest of the mountain at 1451 MDT.

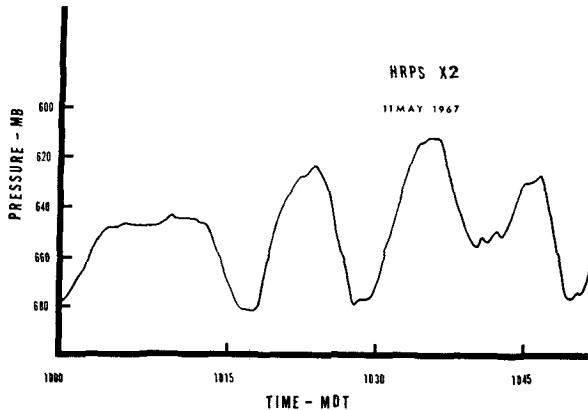

FIG. 10. A series of waves shown to the lee of the mountains. The ascent and floating-altitude portion of the balloon flight are shown prior to the mountain. Notice the fine detail that is available. The balloon passed over the crest of the mountain at 1014 MDT.

An unusual case is shown in Fig. 9 where the HRPS recorded a decrease in pressure in the lee of the moun-

tain rather than an increase, present in typical mountain lee waves. Fig. 10 shows a series of mountain waves.

HRPS modification in conjunction with a "dangling" thermistor results in obtaining continuous temperature and pressure data from radiosondes flown on super-pressure balloons, thus making possible the delineation of the streamflow during mountain wave investigations. These two modifications turn the radiosonde into a practical and inexpensive research tool for the research meteorologist.

#### REFERENCES

- Lamberth, Roy L., Ralph D. Reynolds and Morton G. Wurtele, 1965: Mountain lee waves at White Sands Missile Range. *Bull. Amer. Meteor. Soc.*, **46**, 634-636.
- Reynolds, Ralph D., and Roy L. Lamberth, 1966: Ambient temperature measurements from radiosondes flown on constant-level balloons. *J. Appl. Meteor.*, **5**, 304-307.
- Suomi, V. E., K. J. Hanson and R. J. Parent, 1967: The "chirp" digital radiosonde. *J. Appl. Meteor.*, **6**, 195-198.